

GENUINE Remote engine start

INSTALLATION INSTRUCTIONS



Thank you for purchasing a genuine Mazda accessory.

Before removal and installation, be sure to thoroughly read these instructions.

Please read the contents of this booklet in order to properly install and use the Remote engine start. Your safety depends on it.

Keep these instructions with your vehicle records for future reference.

WARNING

- There are several  **WARNING** and  **CAUTION** sections in this booklet concerning safety when installing or removing the Remote engine start. Always read and follow them in order to prevent injuries, accidents, and possible damage to the vehicle.

 **WARNING:** Indicates a situation in which serious injury or death could result if the warning is ignored.

 **CAUTION:** Indicates a situation in which bodily injury or damage to the vehicle could result if the caution is ignored.

- For areas indicating the tightening torque in this instruction manual, tighten to the specified torque using a torque wrench. For areas in which the tightening torque is indicated inside parentheses (), the tightening torque is indicated as a reference value, however tightening using a torque wrench is not necessary.
- Do not modify the Remote engine start.
- Do not install the Remote engine start in any way other than described in the following instructions.
- If in any doubt, please ask your Mazda dealer to install the accessory in order to prevent errors in installation.
- If you have any questions about the use of the accessory, ask your Mazda dealer for proper advice before using it.
- Mazda and its suppliers are not responsible for injuries, accidents, and damage to persons and property that arise from the failure of the dealer or installer to follow these instructions.
- To ensure safety and reliability of the work, installation, removal and disposal work must be carried out by an Authorized Mazda Dealership.
- Be careful not to lose removed parts, and be sure that they are kept free from scratches, grease or other dirt.

PART NAME:	Remote engine start
VEHICLE:	MAZDA3
PART NUMBER:	C930 V7 620A (CONTROLLER KIT) BHP1 V7 630 (HARNESS KIT) [KD53 V7 629 (Hood Switch)]

NOTE

To the dealer

- Please turn over these instructions to the customer after installation.

To the customer

- Keep these instructions after installation. The instructions may be necessary for installing other optional parts or removal of this accessory.
- Should the vehicle or this accessory be resold, always leave these instructions with it for the next owner.
- When the remote engine start is removed, clear the remote engine start information programmed to the vehicle by following the clearing procedure for the advanced key in the workshop manual. In addition, after clearing, the advanced key has to be programmed again.

1. PARTS

▼ Installation view

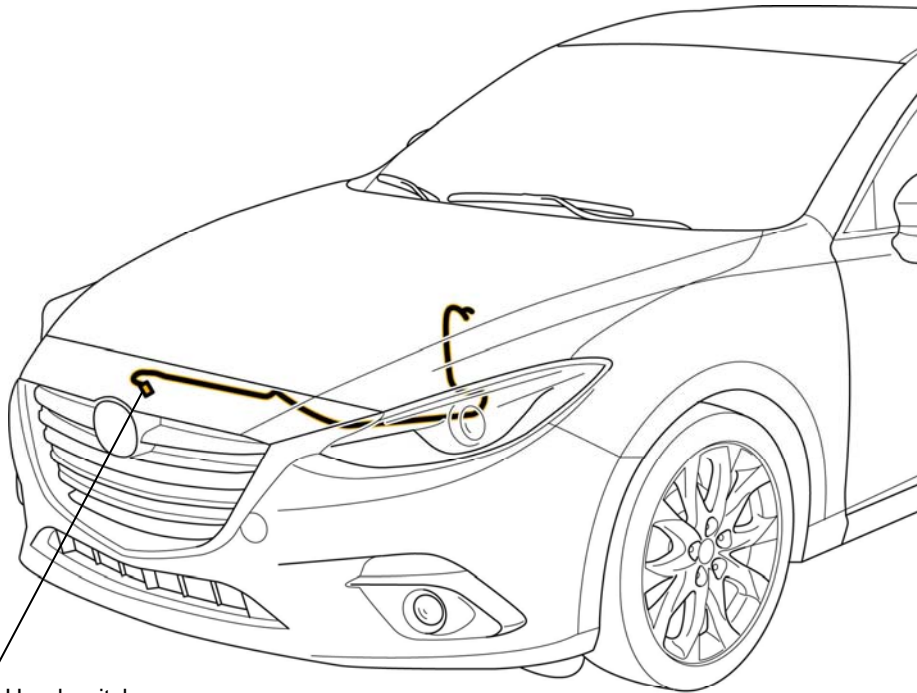

(Sold separately) Hood switch
(Only for vehicle without theft-deterrent or without i-ELOOP system)

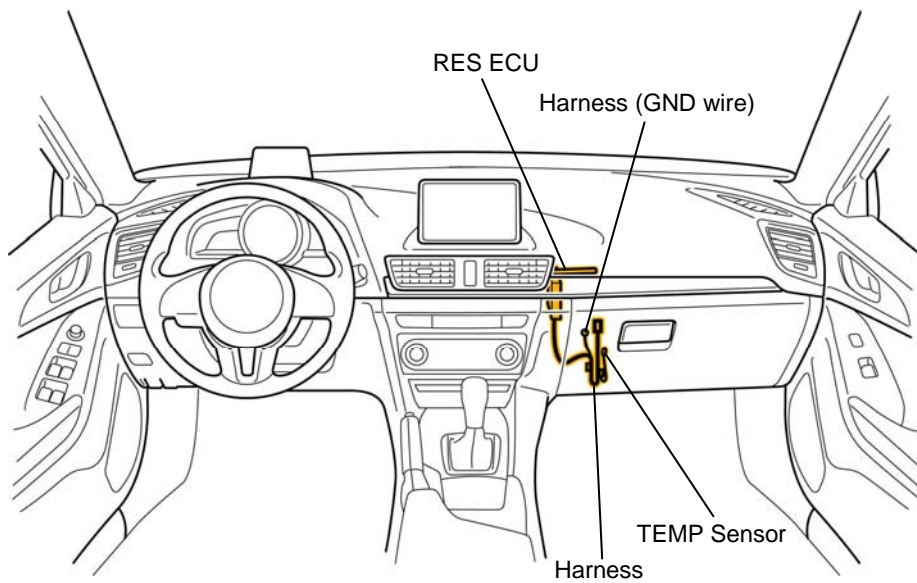



▼ Parts list





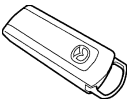
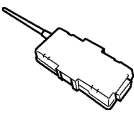
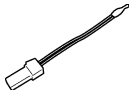



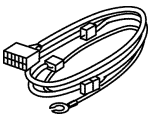

Note

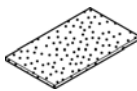
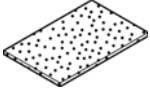
- Verify that the kit includes all the following parts and that the parts are not dirty, scratched, or damaged.

● CONTOROLLER KIT (Part No. C930 V7 620A)

Part	Part name	Qty.	Part	Part name	Qty.	Part	Part name	Qty.
	Remote Start Transmitter (C930 V7 621)	1		RES ECU	1		TEMP Sensor	1
	Double-sided adhesive tape	1		Owner's manual	1			

● HARNESS KIT (Part No. BHP1 V7 630)

Part	Part name	Qty.	Part	Part name	Qty.	Part	Part name	Qty.
	Harness	1		★ Mount base	2		Urethane tape 【60 × 120mm】	1
	Urethane tape 【70 × 100mm】	2		Double-sided adhesive tape	1		★ Electro tap	1
	Tie wrap (White) 【L=200mm】	1		★ Tie wrap (Black) 【L=200mm】	9		Tie wrap (White) 【L=292mm】	1
	Installation instructions	1		Installation inspection sheet	1			



★ : Parts marked with a star mark are only used on vehicles without theft-deterrent or without i-ELOOP system.

(Sold separately) * The following parts are also necessary for installation.

Note

- These parts are not necessary for vehicles with the theft-deterrent or with i-ELOOP system because the hood switch is already equipped.

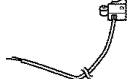
■ Hood Switch (Part No. KD53 V7 629)



Part	Part name	Qty.	Part	Part name	Qty.
	Hood switch	1		Screw	1

2. BEFORE INSTALLATION

■ REQUIRED TOOLS

- ☆ Socket wrench ☆ Torque wrench ☆ Tape-wrapped flathead screwdriver ☆ Nipper ☆ Pliers
- ☆ Scissors ☆ Scale ☆ Electrical vinyl tape ☆ Soft clean cloth ☆ Mat ☆ IPA (Isopropyl alcohol)
- ☆ Primer (3M Promoter-4298)

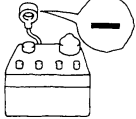
⚠ WARNING

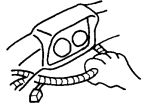
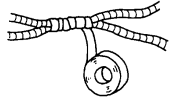
When the negative battery cable is connected during operation, it may cause electric shock or other personal injuries. Disconnect the negative battery cable before removal/installation.	When connecting/disconnecting connectors, grasp the connectors, not the wires. Otherwise a short, an accident from poor contact or fire may occur.	Do not pull the harness with excessive force. Doing so can cause a breakage or a short-related accident, as well as an electrical short or fire.	Secure the harness with the band (part included) so it doesn't dangle. If not, it may cause a short, accident, or fire.
			

⚠ CAUTION

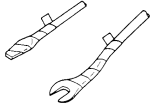
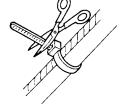
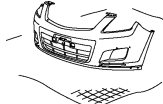
Using improper tools may cause damage and or broken parts. Use the correct tool for the job.	Wrap protective tape around screwdrivers and fastener remover tools to prevent scratching the vehicle.	Excessive length of tie wrap may interfere with other parts and cause damage. Cut unnecessary part up to about 5 mm {0.19 in} from the fixed point.	Put the removed parts and the parts in the kit on the protective sheet to prevent scratches.
			

⚠ WARNING

- When removing/installing the parts, park the vehicle on level ground and apply the side brake securely. Be sure to turn the ignition switch off, otherwise the vehicle can move, causing personal injury or vehicle damage.

Note

- When the negative battery cable is removed, the clock, radio, trip meters and other memories will be erased. Before performing work, record the content of the memory.
- Refer to the Workshop Manual for removal and installation of vehicle parts. Not following the procedures for removal/installation in the Workshop Manual could result in an accident or vehicle malfunction.

3. CONNECTION USING ELECTRO-TAP

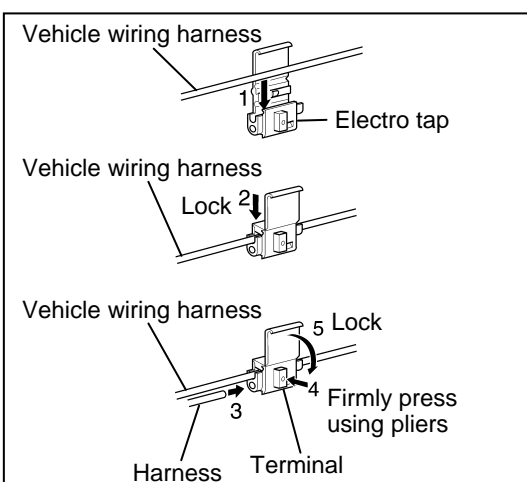

Branch connection procedure using electro tap

1. Insert the vehicle wiring harness into the electro tap.
2. Fold the electro tap as shown in the figure and lock it.

⚠ CAUTION

- Firmly engage the lock part until a click sound is heard.

3. Insert the harness to the end of the electro tap.
4. Firmly press the electro tap terminal using pliers.
5. Fold the electro tap in the direction of the arrow shown in the figure and lock it.

4. CONNECTION DIAGRAM

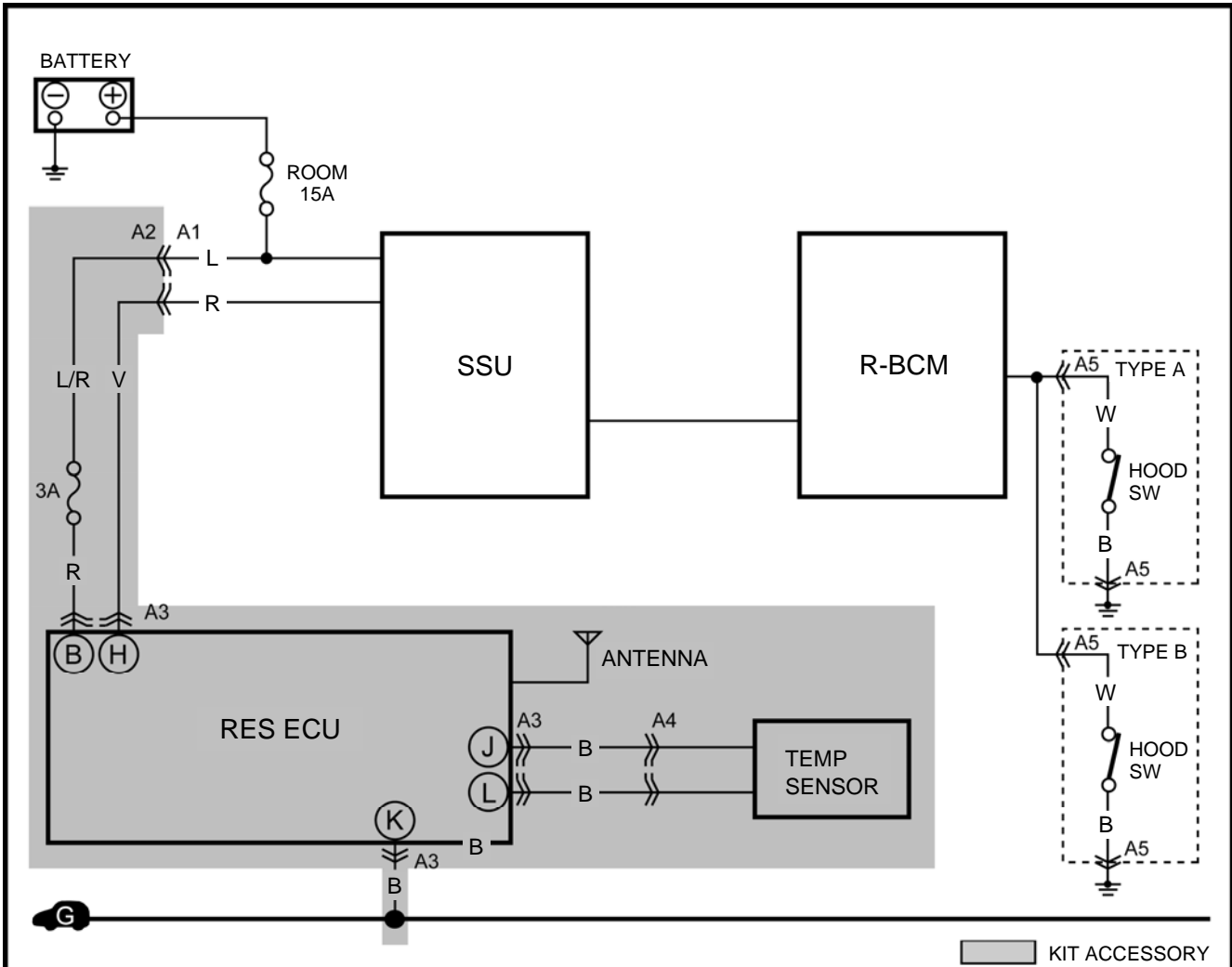

<p>A1 Vehicle Option Harness</p>	<p>A2 Harness</p>
<p>A3 RES ECU</p>	<p>A4 TEMP SENSOR</p>
<p>A5 FUSE BOX</p>	

Figure shows connector viewed from harness side.

5. PART REMOVAL

⚠ CAUTION

- Be careful not to damage or lose any parts removed from the vehicle since they will be reused.

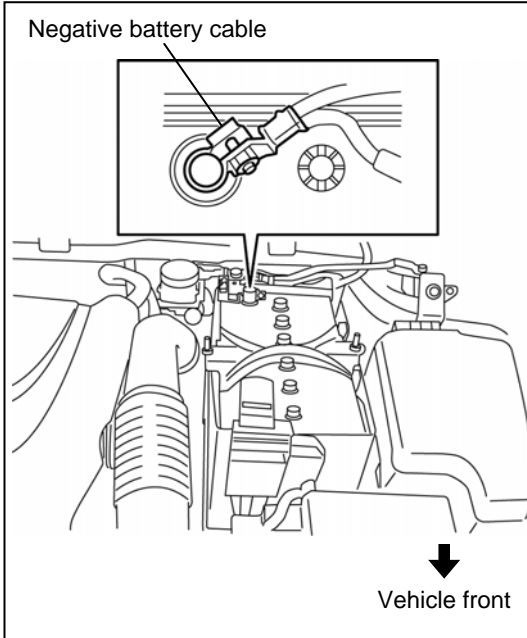

Negative battery cable disconnection

1. Set the selector lever to P range.
(AT vehicles only)

⚠ WARNING

- When removing/installing the parts, park the vehicle on level ground and apply the side brake securely. Be sure to turn the ignition switch off, otherwise the vehicle can move, causing personal injury or vehicle damage.

2. Disconnect the negative battery cable and wrap tape around it to insulate.

⚠ WARNING

- When the negative battery cable is connected during operation, it may cause electric shock or other personal injuries. Disconnect the negative battery cable before removal/installation.

Tightening torque : 4.0 - 6.0 N·m

- Parts ① to ④ are only for vehicles without theft-deterrent or with i-ELOOP system

① Seat plate removal

1. Remove fasteners shown in the figure.

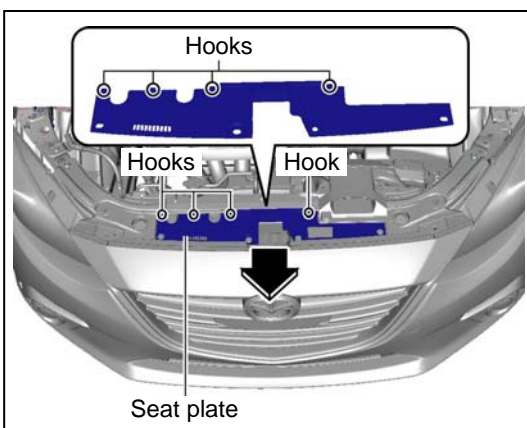
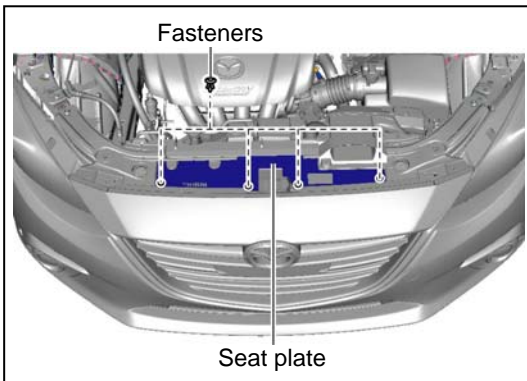

2. Pull the set plate in the direction of the arrow and remove it while detaching hooks.

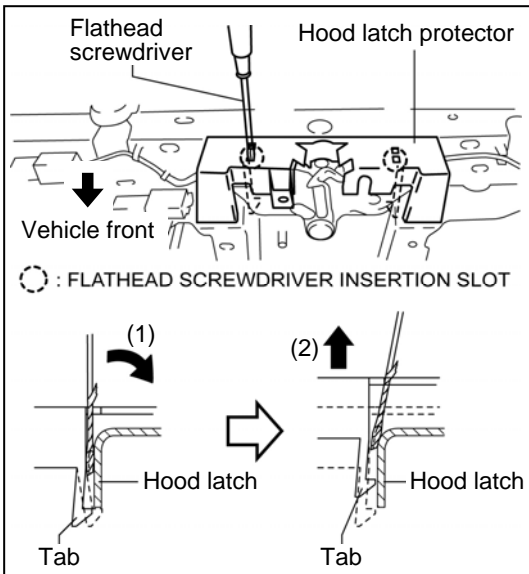

② Hood latch protector removal

1. Insert a tape-wrapped flathead screwdriver into the position shown in the figure.
2. Move the tape-wrapped flathead screwdriver in the direction of arrow (1) shown in the figure to press the hood latch protector tab, and lift the tab up in the direction of arrow (2) and detach its tab from the hood latch.
3. Detach all the hood latch protector tabs from the hood latch and remove the hood latch protector.

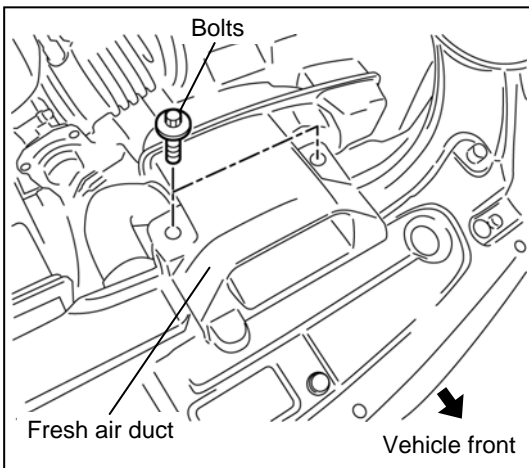

③ Bolt, fastener and screw removal

1. Remove the fresh air duct bolts (2 locations).

Bolt tightening torque : 7.8 - 10.8 N·m

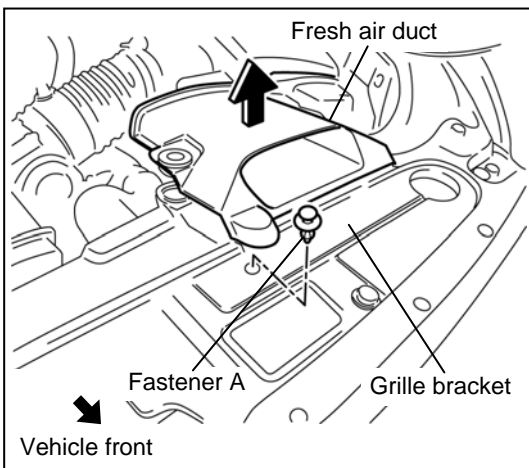

2. Remove the grille bracket fastener A (1 location).

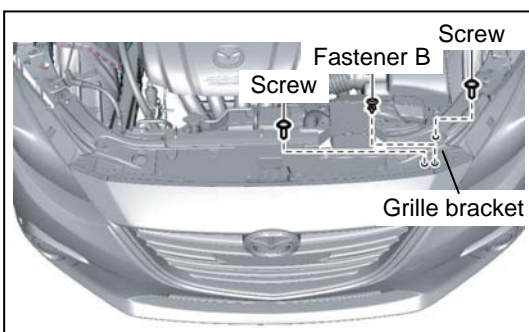

3. Remove the grille bracket fastener B (1 location) and screws (2 locations).

Screw tightening torque : 4.0 - 9.8 N·m

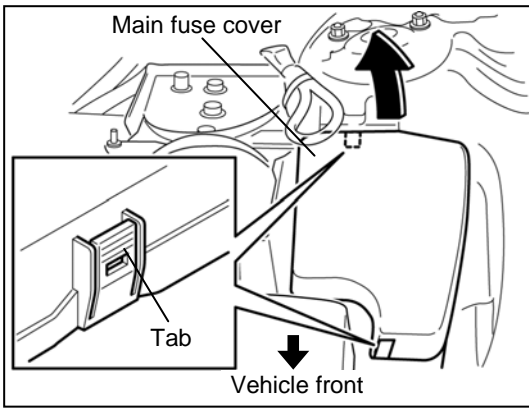

④ Main fuse cover removal

1. Detach the main fuse cover tab (2 locations), and lift the rear part of the main fuse cover to remove it.

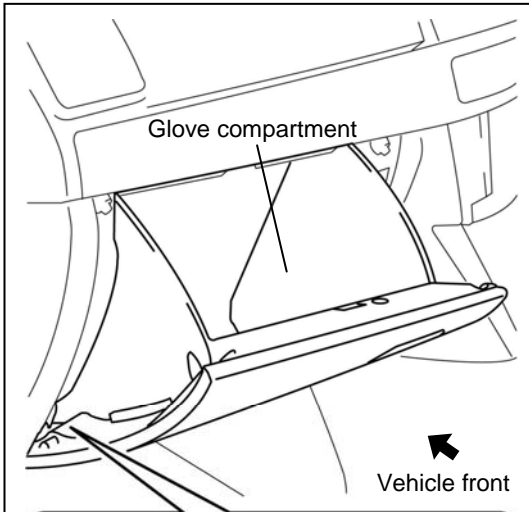

Glove compartment removal

1. Open the glove lid.
2. Pull the stay damper in the direction of the arrow (1) shown in the figure and remove the hook A.

⚠ CAUTION

- If the glove compartment is closed without being joined to the stay damper, the stay damper may be damaged. Verify that the stay damper is joined to the glove compartment before closing the glove compartment.

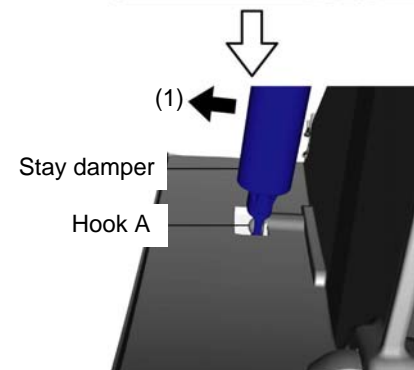
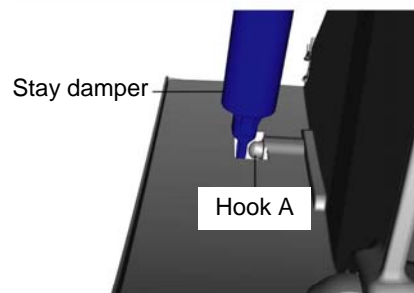
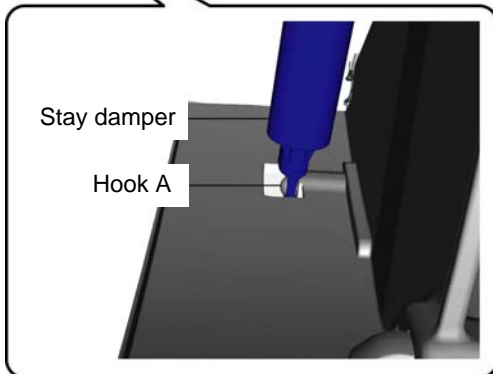

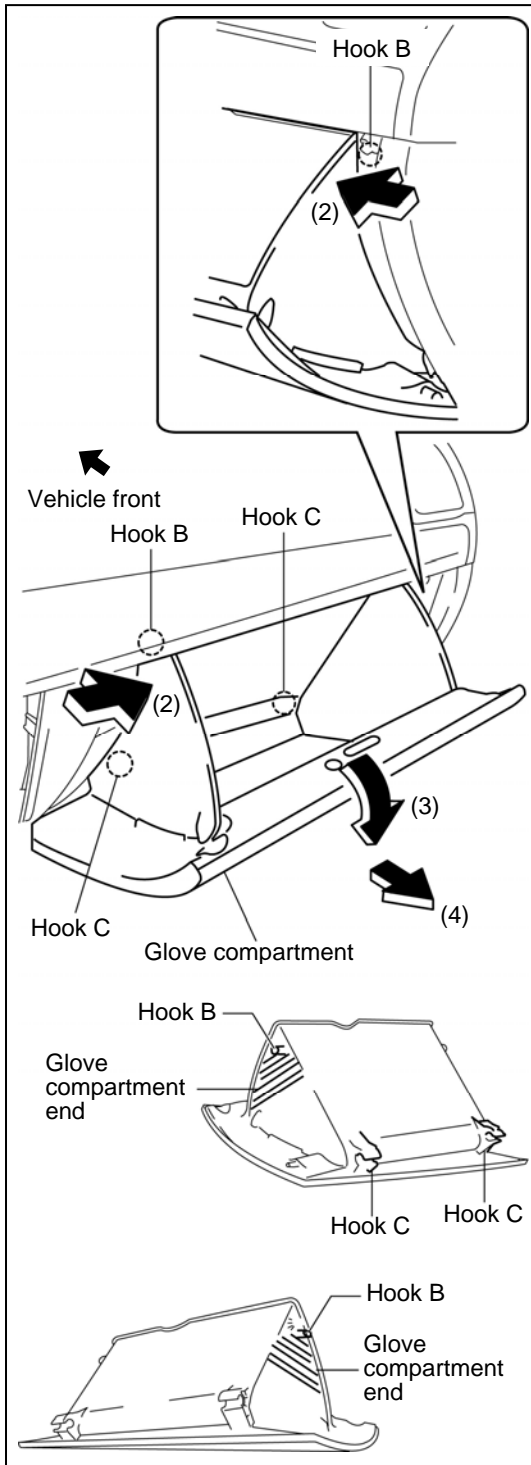

3. Push the glove compartment end in the direction of the arrow (2) and remove hooks B.

CAUTION

- When disengaging hooks B, the hooks could interfere with the lower panel and cause scratches or damage. When removing hooks B, press in the ends of the glove compartment to a location which does not interfere with the lower panel.

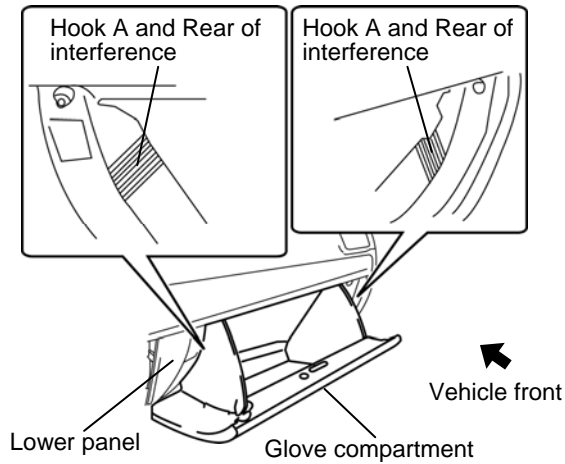

4. Pull down the glove compartment in the direction of the arrow (3).

5. Pull the glove compartment in the direction of the arrow (4) and remove it while detaching hooks C.

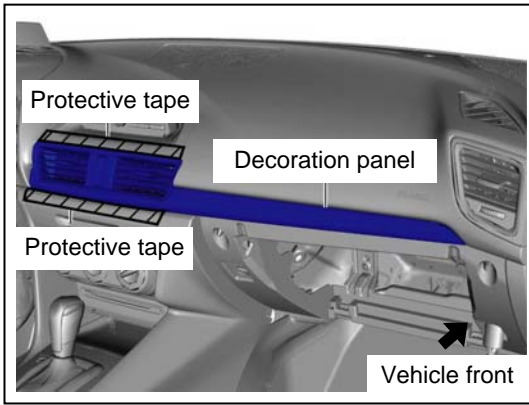

Decoration panel removal

⚠ CAUTION

- To prevent scratches or damage, apply protective tape to the position shown in the figure.

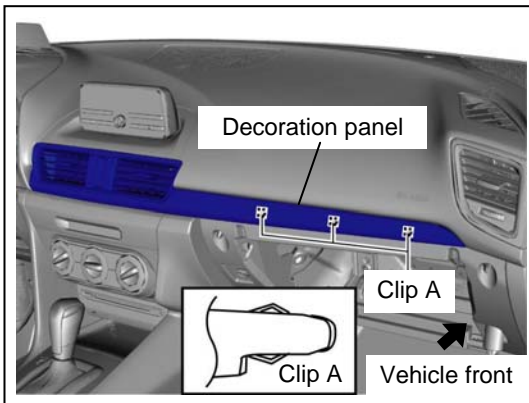

1. Insert a hand into the glove compartment opening and press out clips A shown in the figure towards the rear of the vehicle.

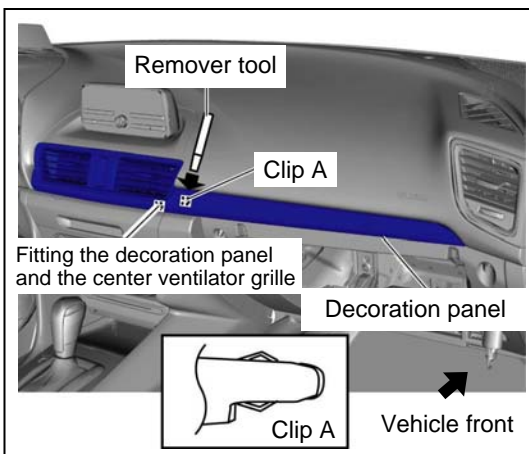

2. Insert a hand into the glove compartment opening, and while pressing clip A with a finger, insert the remover tool into the position shown in the figure, move the decoration panel, and disengage decoration panel clip A from the lower panel.

⚠ CAUTION

- If the decoration panel is pulled with excessive force when disengaging clip A, the center ventilator grille and decoration panel connection could be damaged. When disengaging clip A, be careful not to damage the decoration panel.

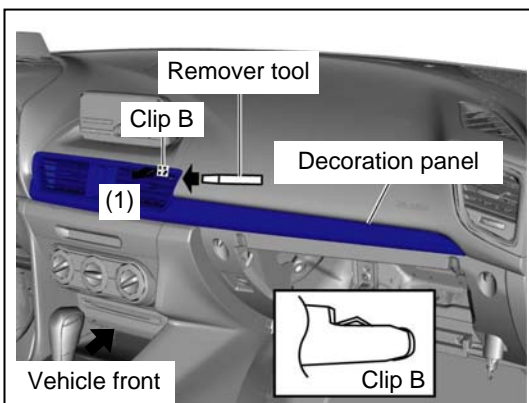

3. Insert the remover tool into the position shown in the figure and move the decoration panel in the direction of arrow (1) shown in the figure, and disengage clip B from the dashboard.

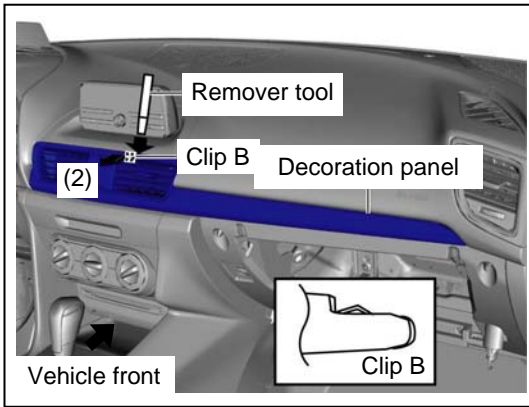

4. Insert the remover tool into the position shown in the figure, move the decoration panel in the direction of arrow (2) shown in the figure, and remove clip B from the dashboard.

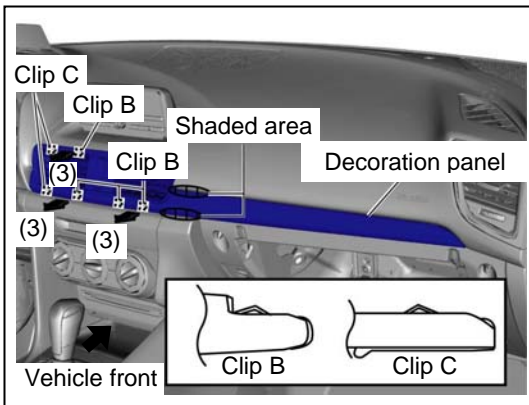

5. Hold the shaded areas shown in the figure, pull the decoration panel straight out in the direction (towards rear of vehicle) of arrows (3) shown in the figure, and disconnect clips B, clips C from the instrument panel.

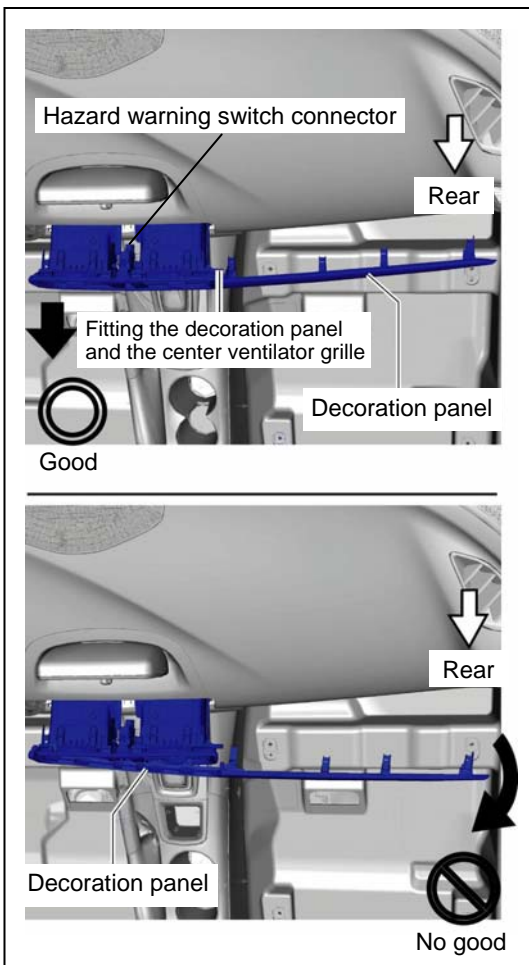

6. Disconnect the hazard warning switch connector.

CAUTION

- If the decoration panel is pulled out while tilted, the center ventilator grille and decoration panel connection could be damaged. Pull the decoration panel straight out toward the rear of the vehicle when removing.

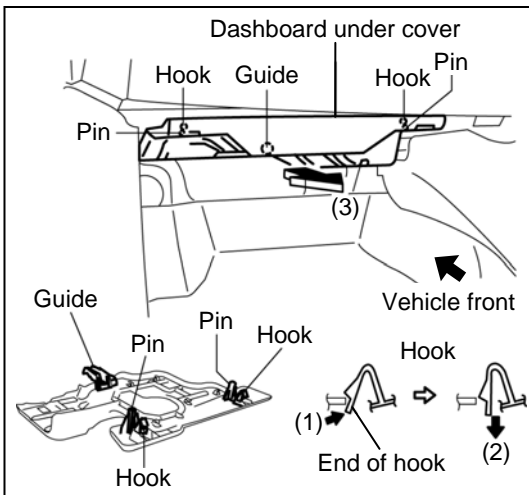

Dashboard under cover removal

1. Detach hooks in the direction of the arrows in the order of (1), (2) shown in the figure.

⚠ CAUTION

- If the decoration panel is pulled out while tilted, the center ventilator grille and decoration panel connection could be damaged. Pull the decoration panel straight out toward the rear of the vehicle when removing.

2. Remove the dashboard under cover in the direction of the arrow (3) shown in the figure while detaching the guide.

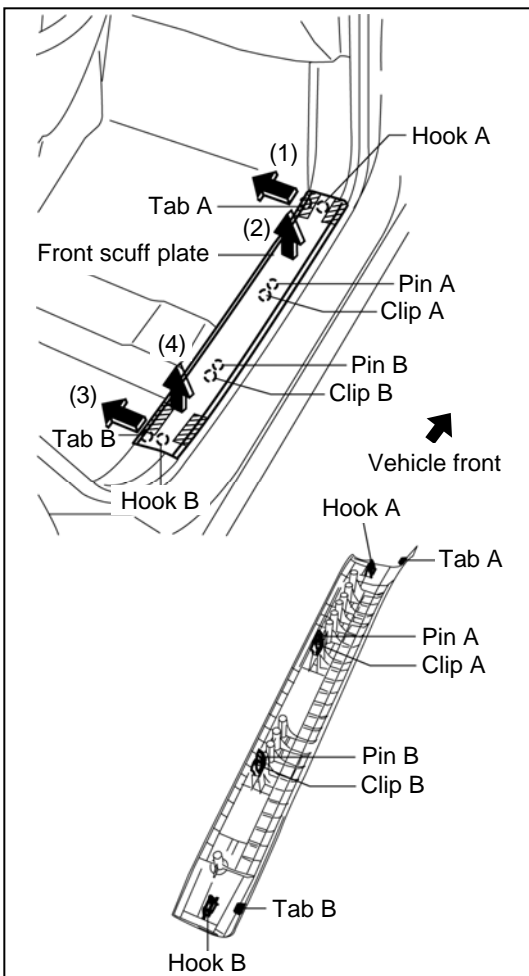

Front scuff plate (Passenger's side) removal

1. Grasp the shaded area shown in the figure, detach tab A while pulling the front scuff plate in the direction of the arrow (1) shown in the figure, then detach the hook A, clip A, and pin A while pulling in the direction of the arrow (2).
2. Grasp the shaded area shown in the figure, detach tab B while pulling the front scuff plate in the direction of the arrow (3) shown in the figure, then detach the hook B, clip B and pin B while pulling in the direction of the arrow (4).

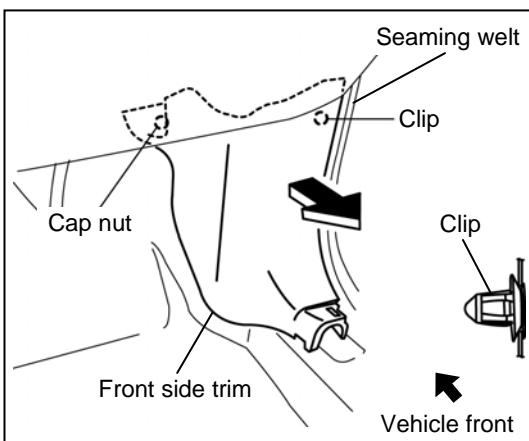

Front side trim (Passenger's side) removal

1. Partially peel back the seaming welt.
2. Remove the cap nut.
3. Pull the front side trim in the direction of the arrow shown in the figure and remove it while detaching the clip.

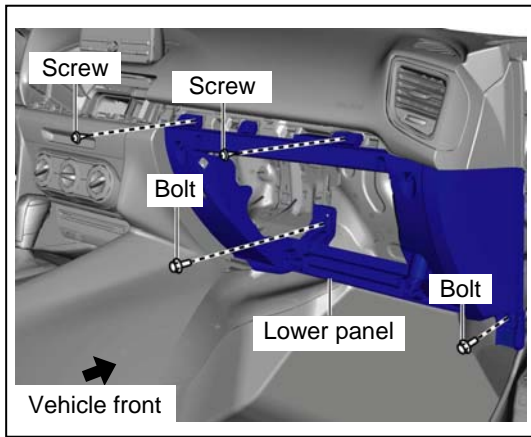

Lower panel (passenger's side) removal

1. Remove bolts.
2. Remove screws.

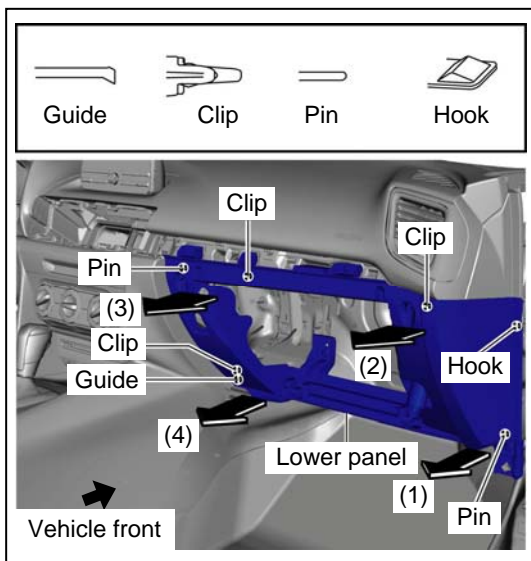

3. Pull the passenger-side lower panel in the direction of the arrow in the order of (1), (2), (3), (4) and remove it while detaching clips, hook, pin and guide.

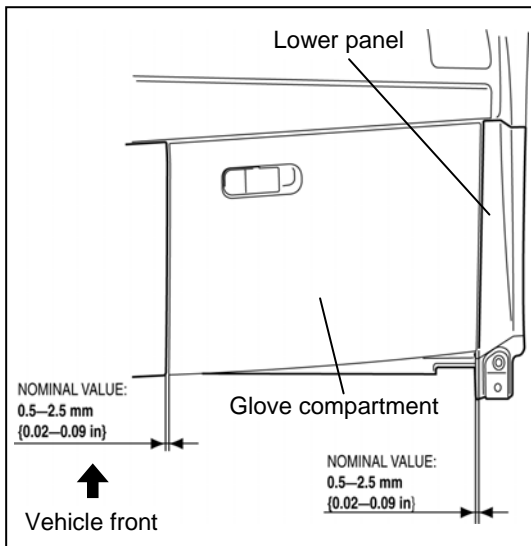

■ Lower panel (passenger's side) installation note

- After installing the passenger-side lower panel and glove compartment, measure the clearance, and verify that the measurement value is within the specification shown in the figure.

⚠ CAUTION

- If the measurement value is not within the specification after measuring the clearance between the passenger-side lower panel and glove compartment, adjust the passenger-side lower panel to the proper position.

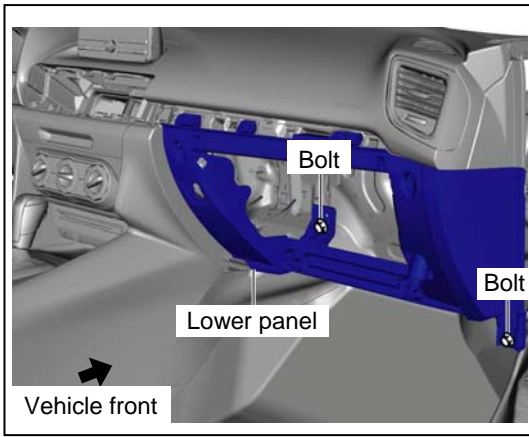

■ Lower panel (passenger's side) adjustment

1. Loosen bolts.

⚠ CAUTION

- If the passenger-side lower panel moves in the lateral direction when bolts are loosened, go to the Step 3 and 4.
- If the passenger-side lower panel does not move in the lateral direction when bolts are loosened, go to the Step 5.

2. Remove bolts.

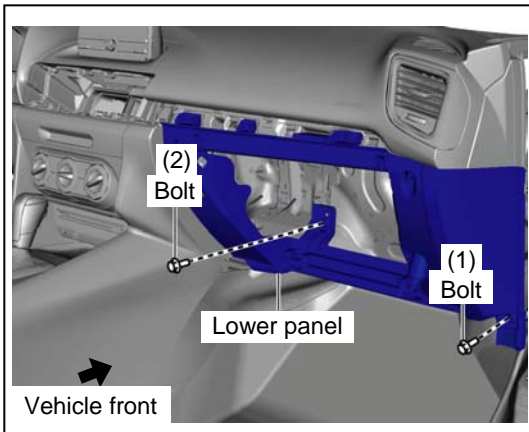

3. Install bolts in the order of (1), (2) shown in the figure.

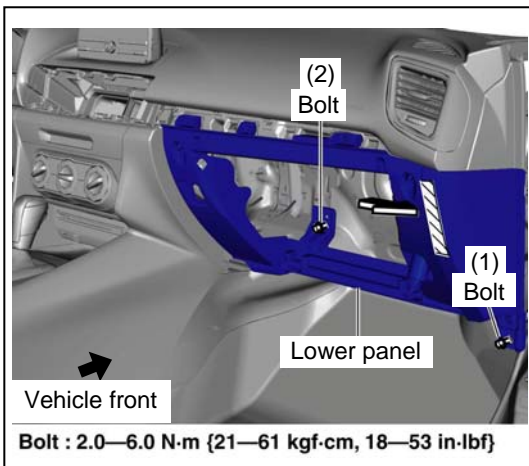

4. Install bolts in the order of (1) and (2) while pressing the shaded area shown in the figure for the passenger-side lower panel.

5. Install the glove compartment, measure the clearance between the glove compartment and passenger side lower panel again, and verify that it is within the specification.

⚠ CAUTION

- If it is not within the specification after measuring the clearance, repeat the adjustment procedure from Step 1.

6. HOOD SWITCH INSTALLATION

Note

- This procedure is not necessary for vehicles with the theft deterrent or with i-ELOOP system because the hood switch is already installed.

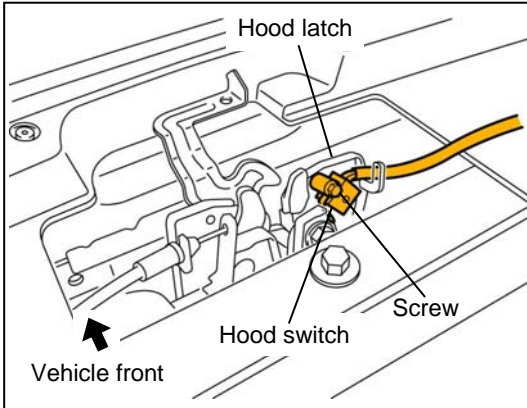

1. Install the hood switch to the hood latch and secure it using a screw (1 location).

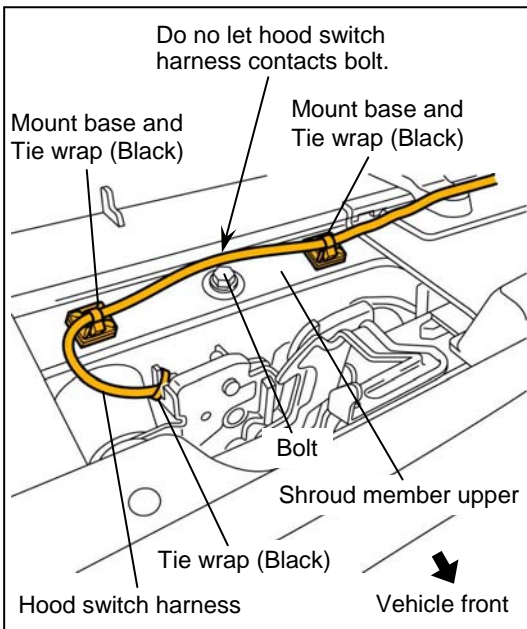

2. Hook the hood switch harness to the hood latch and secure it using a tie wrap (Black) at one location.
3. Install tie wraps (Black) to the mount bases and temporarily tighten the hood switch harness at two locations.

⚠ CAUTION

- Do not tighten the tie wrap (Black) so much that the hood switch harness cannot move.

4. Peel back the tape backings on the back of the mount bases and affix the mount bases on the shroud member upper at two locations with the hood switch harness routed as shown in the figure.

⚠ CAUTION

- Place the tightening part of the tie wrap (Black) downward and secure. Otherwise, it may not be possible to re-install the seat plate.

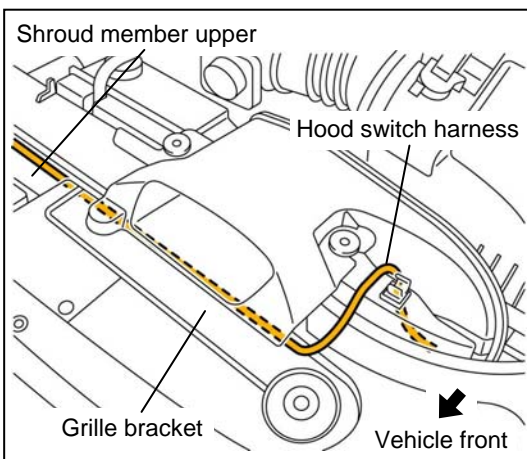
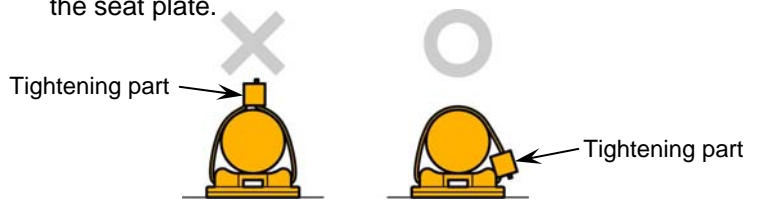

5. Pass the hood switch harness between the grille bracket and the shroud member upper.

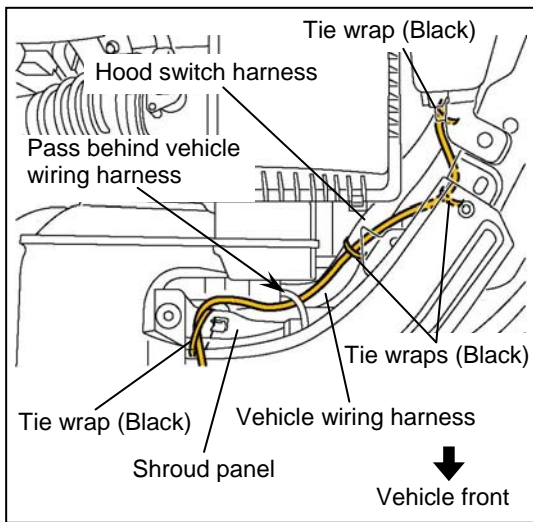

6. Secure the hood switch harness to the shroud panel using tie wraps (Black).
7. Route the hood switch harness along the vehicle wiring harness and secure it using a tie wraps (Black) at two locations.
8. Secure using a tie wrap (black) in the body hole next to the vehicle wiring harness.

⚠ CAUTION

- Secure the hood switch harness on the vehicle wiring harness so that the hood switch harness does not contact the vehicle edge.

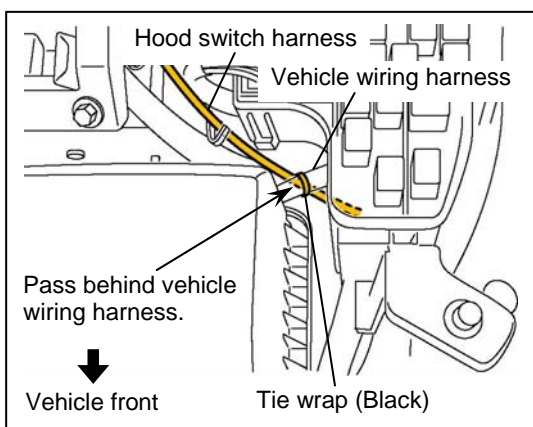

9. Route the hood switch harness along the vehicle wiring harness and secure it using a tie wrap (Black) at one location.

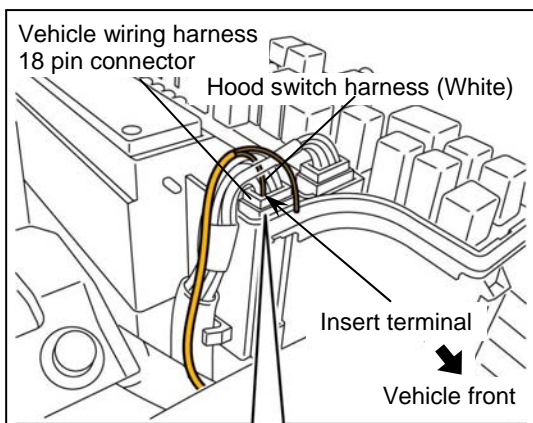

10. Insert the hood switch harness (White) terminal to the empty terminal of the vehicle wiring harness 18 pin connector (terminal N).

⚠ CAUTION

- When connecting a terminal to a connector, always refer to the following <Terminal insertion procedure>.
- Connect the harness terminal to the specified signal line because a system or vehicle malfunction may occur if it is connected incorrectly.

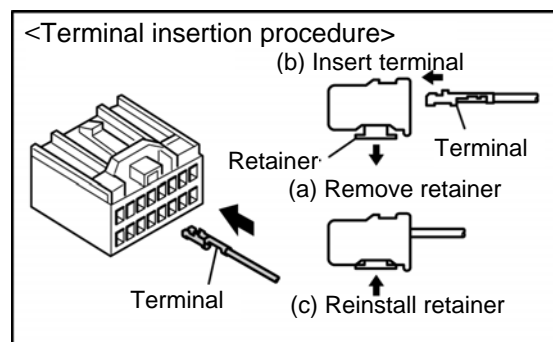
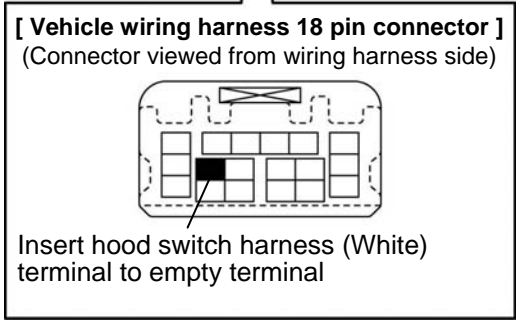

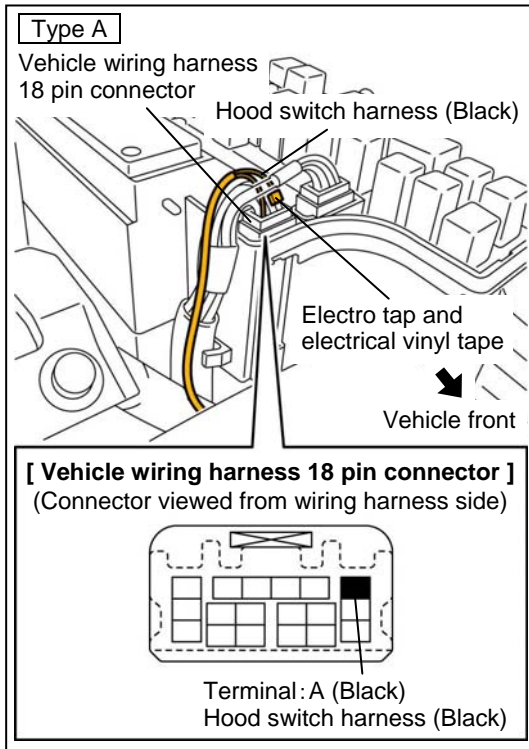

Vehicles with wiring harness terminal A (Black) shown in figure (Type A)

- Branch connect the hood switch harness (Black) to the vehicle wiring harness 18 pin connector (terminal A (Black)) using an electro tap, and wrap the electro tap using electrical vinyl tape.

⚠ CAUTION

- Connect the electro tap to the specified signal line because a system or vehicle malfunction may occur if it is connected incorrectly.
- For branch connection procedure using electro tap, refer to [3. CONNECTION USING ELECTRO TAP] on page 4.

Note

- If there is no vehicle wiring harness (Black) in the specified position, do not perform Step 12 and go to Step 13.

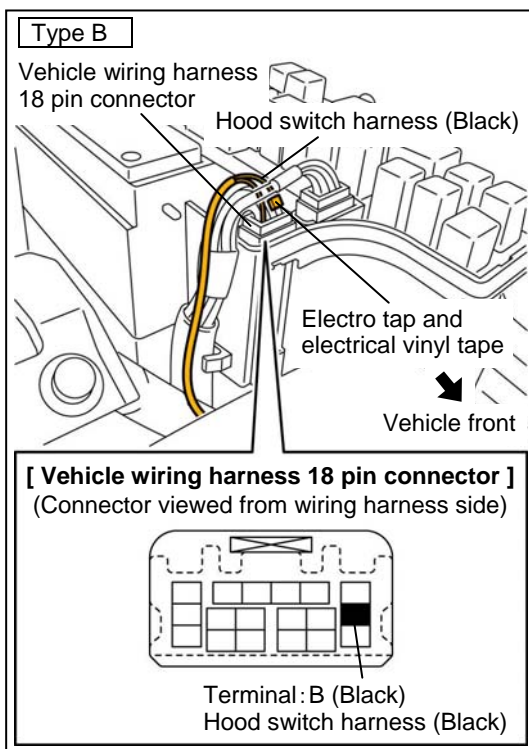

Vehicles with wiring harness terminal B (Black) shown in figure (Type B)

- Branch connect the hood switch harness (Black) to the vehicle wiring harness 18 pin connector (terminal B (Black)) using an electro tap, and wrap the electro tap using electrical vinyl tape.

⚠ CAUTION

- Connect the electro tap to the specified signal line because a system or vehicle malfunction may occur if it is connected incorrectly.
- For branch connection procedure using electro tap, refer to [3. CONNECTION USING ELECTRO TAP] on page 4.

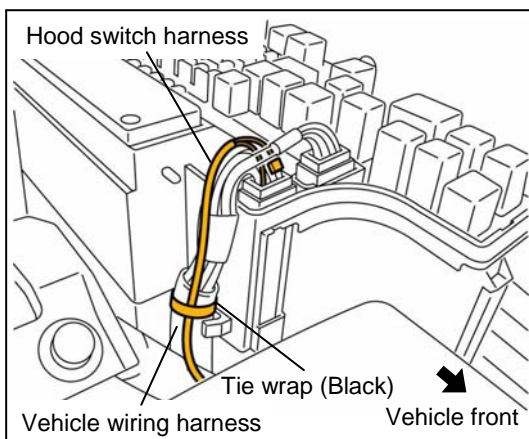

- Route the hood switch harness along the vehicle wiring harness and secure it using a tie wrap (Black) at one location.

7. REMOTE ENGINE START INSTALLATION

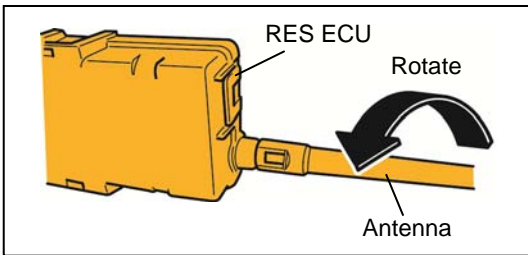

1. Rotate the RES ECU antenna and align the opening in the direction shown in the figure so that the antenna is collapsible.

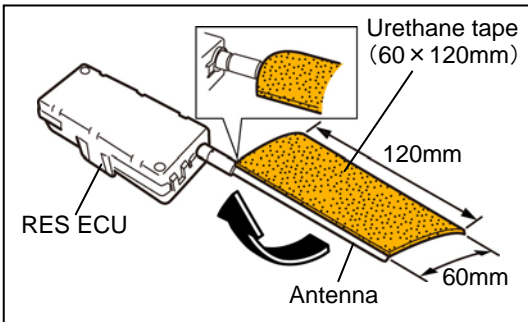

2. Wrap urethane tape (60x120mm) around the antenna.

CAUTION

- Because the antenna is retractable, it may cause noise. Wrap urethane tape from the collapsible part of the RES ECU to the end of the antenna.
- Cut urethane tape to the length from the end of the RES ECU to the end of the antenna and use.

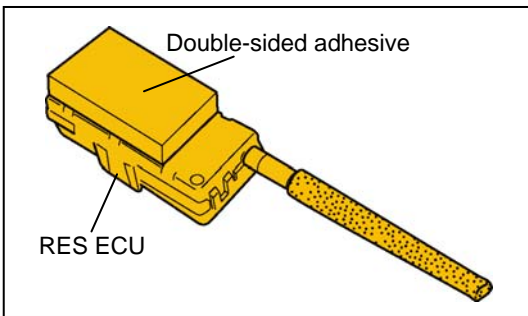

3. Degrease the RES ECU using primer, and affix double-sided adhesive tape.

CAUTION

- Use 3M Promoter-4298 for primer.
- When degreasing using primer, only apply primer to the degreased area to prevent other parts from becoming discolored.
- After degreasing using primer, let it dry for 1 min. or more.
- Affix double-sided adhesive tape firmly.

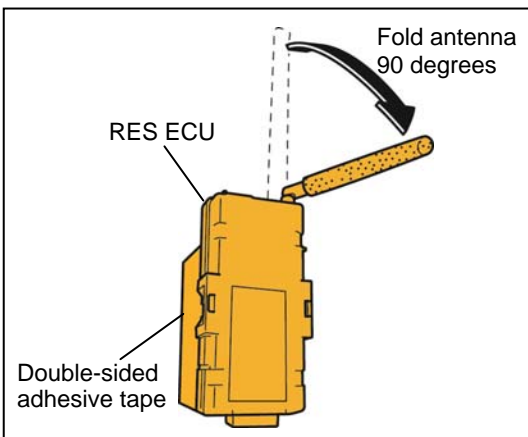

4. Fold the RES ECU antenna 90 degrees as shown in the figure.

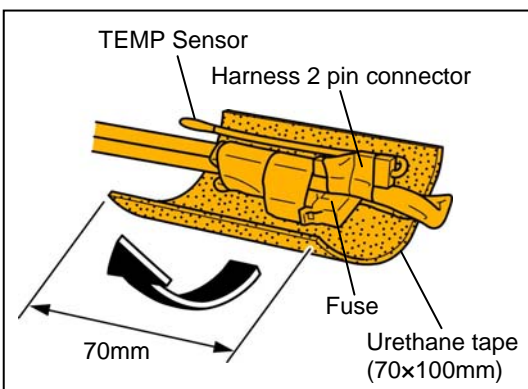

5. Connect the TEMP sensor to the harness 2 pin connector.
6. Wrap the wiring harness and the TEMP sensor and the fuse using the urethane tape (70x100mm).

CAUTION

- Do not wrap urethane tape around the sensor part of the TEMP sensor. The sensitivity of the sensor may be affected if it is wrapped.

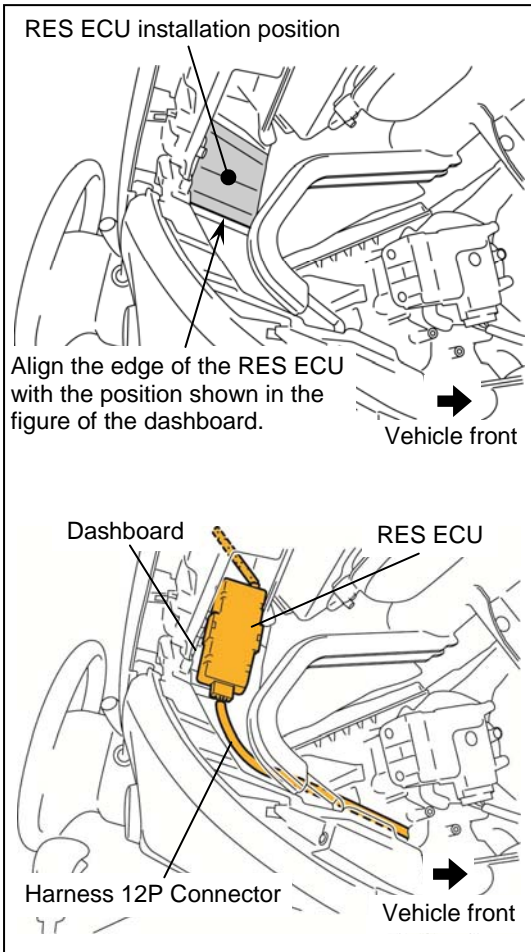

7. Connect the harness 12 pin connector to the RES ECU.
8. Degrease the RES ECU installation position at the upper back of the glove compartment (dashboard) using primer, and affix double-sided adhesive tape of the RES ECU.

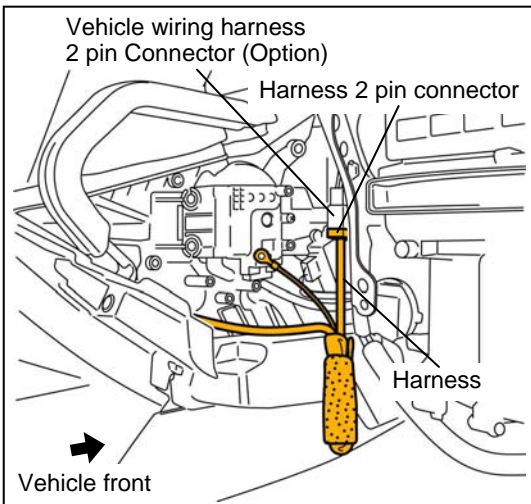
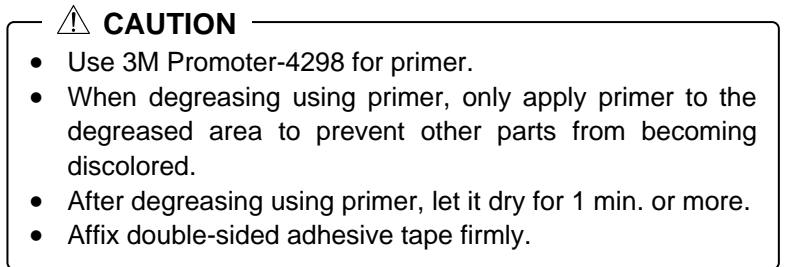
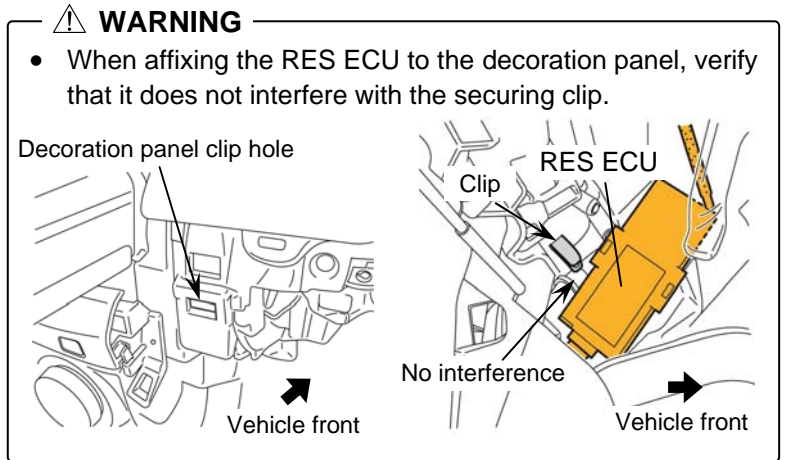

9. Connect the harness 2 pin connector to the vehicle wiring harness 2 pin Connector (Option).

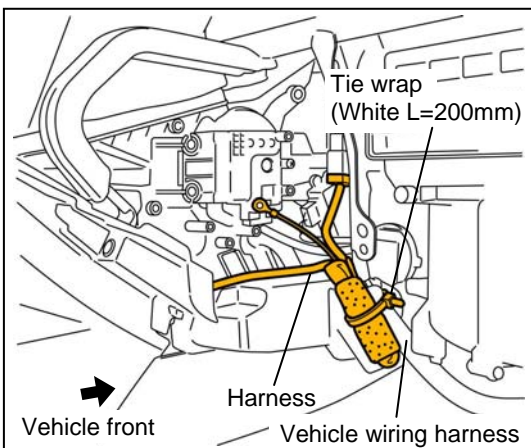
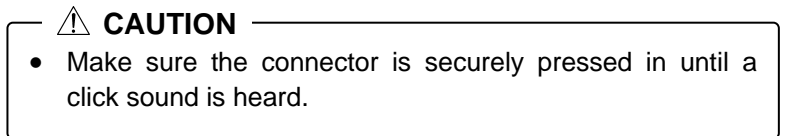

10. Secure the harness to the vehicle wiring harness using a tie wrap (White L=200mm).

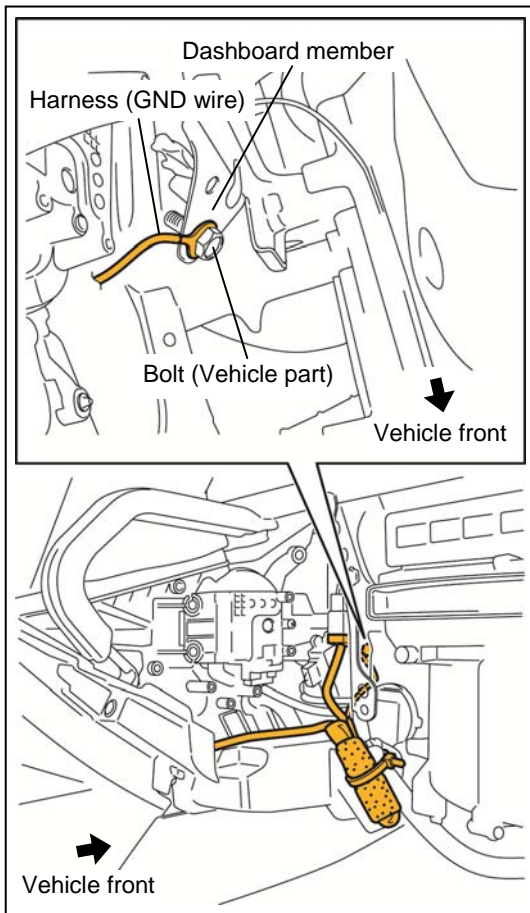

11. Tighten the dashboard member bolt (vehicle part) together with the harness (GND wire) which is routed below the glove compartment.

Bolt tightening torque : 8.8—12.7 N·m

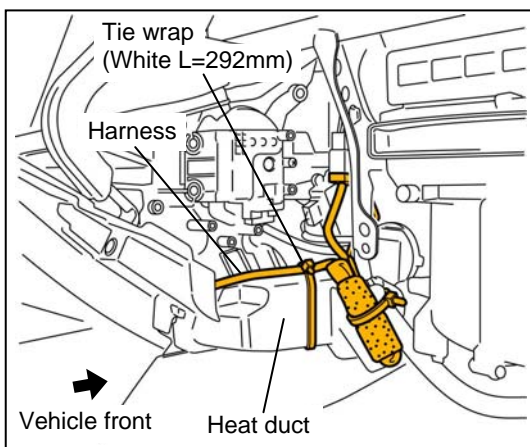

12. Pull the harness to the top of the heat duct and secure it with a tie wrap (White L=292 mm)

CAUTION

- When routing the harness, do not allow it to interfere with the heater unit core and always secure it to the top surface of the heat duct.

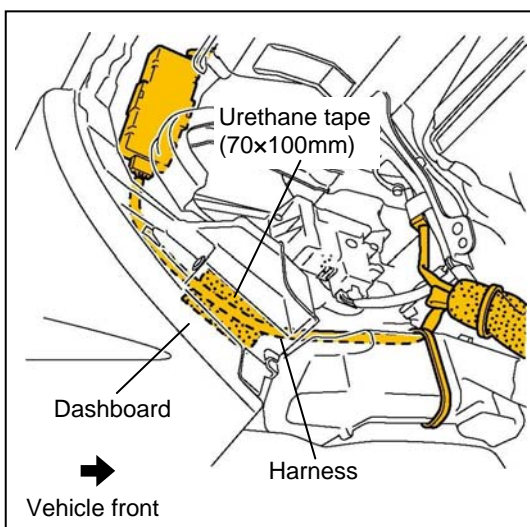

13. Secure the harness to the underside of the dashboard using urethane tape (70 x 100 mm).

CAUTION

- Always remove dirt or oil because the adhesive strength of the urethane tape weakens.

9. OPERATION CHECK

1. Register the controller (= RES ECU) with reference to the attached sheets "GENUINE REMOTE ENGINE START 【Parts No. C930 V7 620A】 Registration Procedure Of the Controller".
2. Perform the Vehicle status check with the remote control (= Remote Start Transmitter), and verify the "Stop" mark is appeared and Error display " t " is not appeared on the LCD monitor of it when it receives a response from the vehicle.
3. Perform the Engine start operation with the remote control, and verify the vehicle engine is started.
4. If Steps 2 to 4 cannot be completed successfully, refer to the "Troubleshooting manual" issued by Mazda.
※ The troubleshooting manual is posted on the site for servicing personnel.